



REPUBLIC OF THE PHILIPPINES
POLOMOLOK WATER DISTRICT

National Highway, Polomolok, South Cotabato
Tel Nos. (083) 500-9261 ; 500-9314 ; 500-9430
Telefax No. (083) 500-8008
Email Address : pol_wd@yahoo.com.ph



BID BULLETIN NO. 2

**Additional Instructions to all Prospective Bidders for
the
Construction of Polomolok Water Supply System
Improvement Project**

1. On web and section detail, length of River Crossing was changed from 38.78 to 48.78 meters (Section AAA). Please see attached drawing for your reference.

ENGR. CECIL D. MIRASOL
BAC Chairman



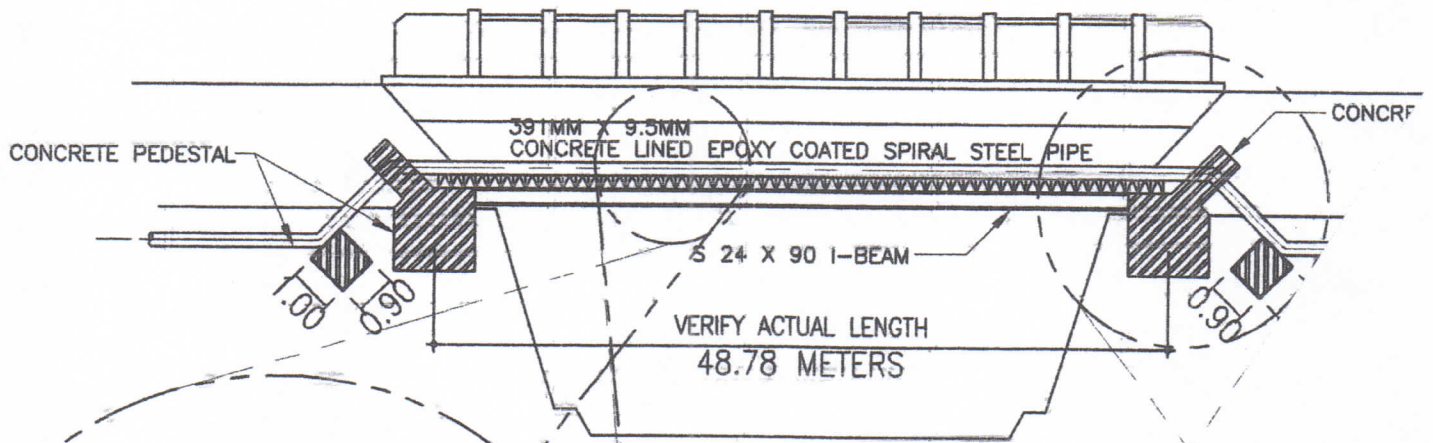

1 SECTION "AA-AA"
021 NOT TO SCALE

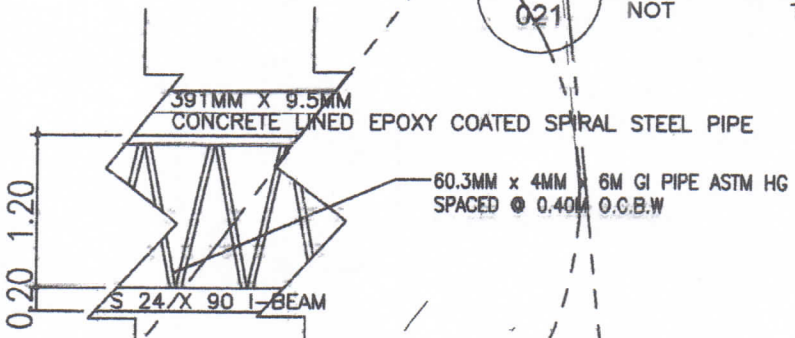

WEB DETAIL

